

## BNS38-D BAYNETS SAFETY SYSTEMS INSTALLATION INSTRUCTIONS

- Heavy Duty
- Single Bay
- Single Pan



### EXTREMELY IMPORTANT:

1. In preparation, be sure that all flammable products have been removed from the service bay and that all paint, grease and debris have been removed from the areas to be welded.
2. Use only a certified welding technician for Steps 2, 3, 4 & 5 who is fully aware of all products specific to your facility and is knowledgeable in safety compliance required to perform these steps.
3. Follow the installation methods exactly to insure the system meets all Occupational Safety and Health Administration specifications.

**STEP 1** Unpack all items from box and identify the following:

- |   |  |
|---|--|
| A. Net (1 per installation)   | F. Snap Hooks, 120 mm (5 per installation)               |
| B. 3/8" Wire Cable length attached to cab-lug (2 per installation)  | G. Wall Anchor Assembly (1 per drain pan)                |
| C. Cable Clamps (6 per installation), Thimbles (2 per installation) | H. Mid-Bay Cable Pad Eyes with Snap Hooks, 80 mm (4 min) |
| D. Turnbuckles (2 per installation)                                 | I. Cab-Lug (2 per installation)                          |
| E. Quick Links (quantity dependant on net length)                   | J. Drain Pan Anchor Assembly (1 per drain pan)           |

**Tools Required:** Tape measure and marker, two vice-grips, two crescent wrenches, torque wrench, cable shears, protective gloves and safety glasses.

**STEP 2** Weld the number one and two cab-lug with the cable attached to the upper right and left corners in a horizontal position. See overall view and assembly Detail A.

- Proceed to the opposite end of the bay and weld the number three and four cab-lugs in a horizontal position with the chamfered corners facing out.

**STEP 3** Weld the mid-bay pad eyes to the side walls of the bay in-line with the corner cab-lugs. Space the pad eyes evenly with no more than 15 ft between pad eyes.

- Attach a 80 mm snap hook to each mid-bay pad eye. See overall view and assembly Detail B.

**STEP 4** Weld two pad eyes to the drain pan as close to in-line as possible with the previously installed cab-lugs. See Detail A showing recommended assembly. The attachment method necessary to be used with your drain pan may vary from the illustration shown.

- Slide the 5/8" steel rod through the two pad eyes and weld into place. If necessary, trim rod ends so they will not interfere with Baynet or drain pan operation.

**STEP 5** Weld the drain pan wall anchor pad eyes into place as shown in Detail A. Provide a 2 inch offset between pad eyes. Attach a snap hook to the drain pan pad eye.

**STEP 6** Unscrew both sides of turnbuckle to its limit, then attach the jaw end of the turnbuckle to the cab-lug (without cable). Repeat on each side. See assembly Detail C.

- Twist open a thimble and attach it to the eye of the turnbuckle; twist closed using two pair of pliers or vice-grips.

**STEP 7** Run the cab-lug attached cable assembly down the length of the bay and through the mid-bay snap hooks. Repeat on each side. See overall view.

- Place three cable clamps on the free end of the cable. Thread the cable through the turnbuckle, around the thimble and through the cable clamps. See Detail D.
- Pull slack out of the wire by hand and tighten one clamp to hold cable in place. Position the cable clamps correctly as shown in Details D & E.
- Tighten and torque the cable clamps to 30 ft-lb. Repeat with the other cable assembly. Trim any excess cable.

**STEP 8** Tighten each turnbuckle with two crescent wrenches, turning with one wrench while holding the cable stationary with the second wrench. Use care not to twist the cable. Tighten the turnbuckle until the cable can be moved no more than 2" vertically at the midway point of the cable.

**STEP 9** Attach net to the cable using quick links along the two long sides every 15" on center. Use the aluminum rings on the net as a guide. See overall view and Detail F.

**STEP 10** Install the 120 mm snap hooks to each corner of net and a center snap hook on the drain pan side. Secure snap hooks as shown to the cab-lugs and drain pan. The spring snap hooks will stay affixed to the net assembly.

- When a technician moves the net, they will unsnap the net from the cab-lugs or drain pan to gain access to either end of the vehicle. See overall view.

**STEP 11** Following installation, your BayNets Safety System should be checked on a regular schedule for tightness of all cables and clamps. The netting should be replaced if it becomes torn or stretched out of shape.



Net  
(1 per installation)



3/8" Wire Cable length  
attached to cab-lug  
(2 per installation)



Cable Clamps  
(6 per installation),  
Thimbles  
(2 per installation)



Turnbuckles  
(2 per installation)



Quick Links  
(quantity dependent  
on net length)



120 mm Snap Hooks  
(5 per installation)



Wall Anchor Assembly  
(1 per drain pan)



Mid-Bay Cable Pad Eyes  
with 80 mm Snap Hooks,  
(4 min per installation)



Cab-Lug  
(2 per installation)

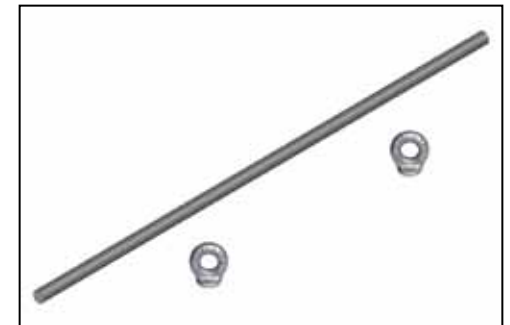

Drain Pan Anchor Assembly  
(1 per drain pan)

InCord BAYNETS provide an easy, effective tool for open pit safety and promote safer work habits in the hazardous area of your service center.

BAYNETS are designed to catch and cradle a person falling into the floor opening. They are fabricated of specially treated, petroleum-resistant synthetic web, installed with aircraft cable and hardware. Once installed, the patented BAYNETS Safety System® has a tensile strength of over 3 tons.



**Detail C**

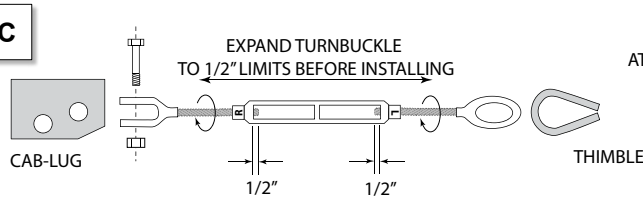

**Detail F**

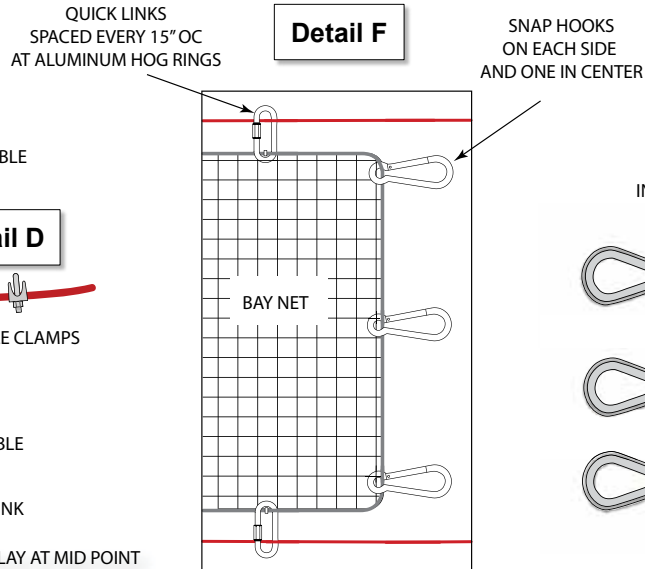

**Detail E**

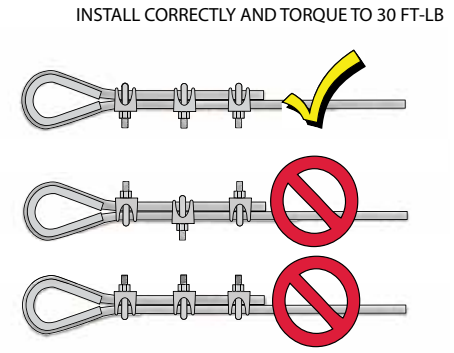

**Detail D**

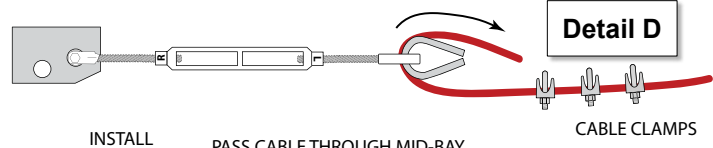

**Detail B**

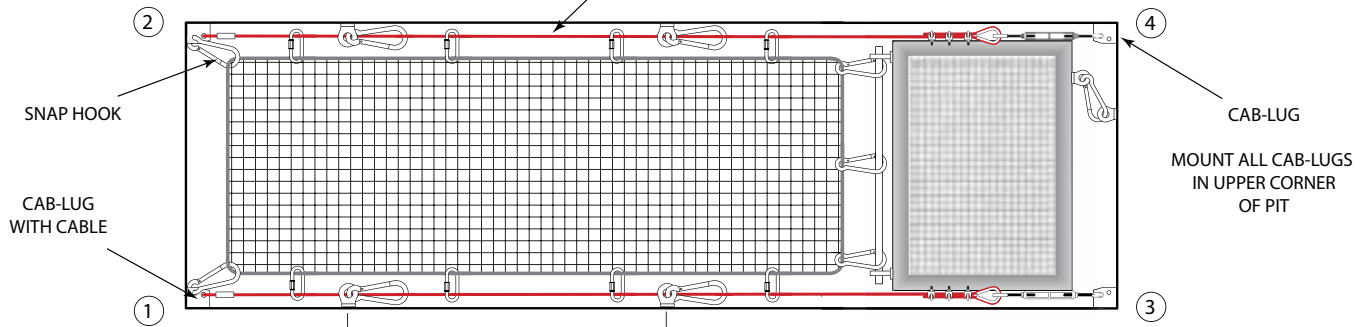
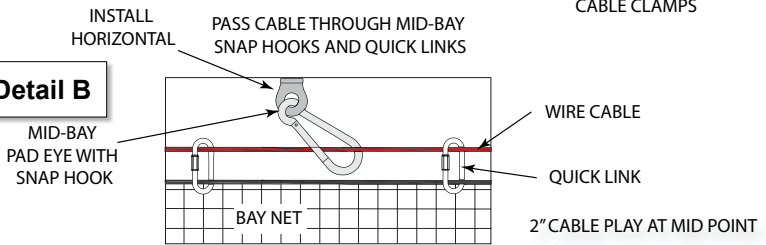

**Main View**



EU Directive: 89/686/EEC  
 EU Standard: EN 1263-1:2002  
 EN 1263-2:2002

**Detail A**

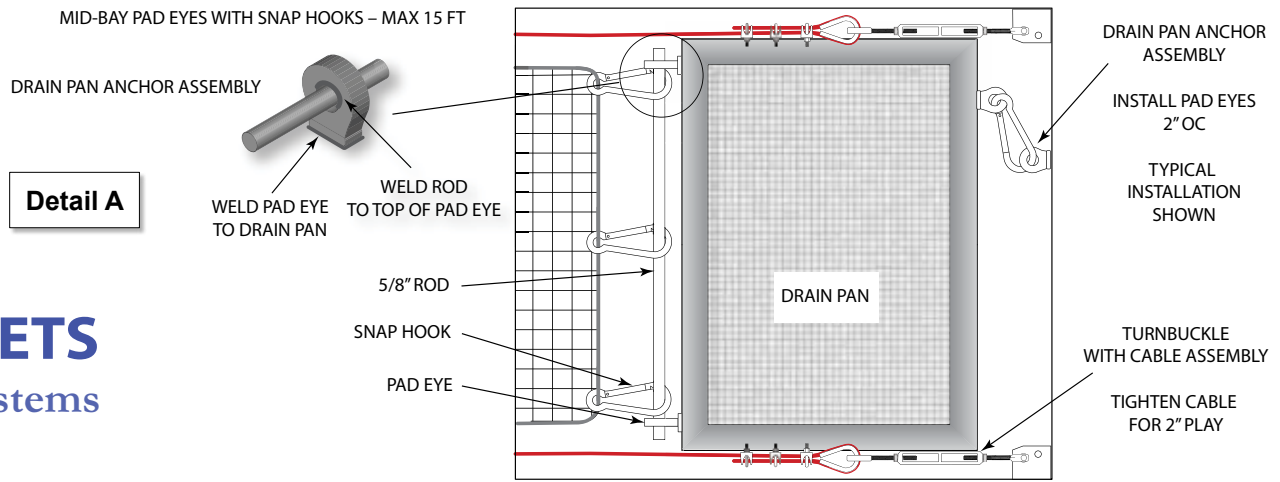

**BAYNETS**  
 Safety Systems

Thank you for purchasing the patented BAYNETS Safety System. We are confident that you will be very pleased with your finished installation and will soon agree that the BAYNETS System is the best safety system for your dollar.

Please read the enclosed installation instructions to verify that all the required hardware has been included. Contact us immediately at 800-331-0731 if any contents are damaged or missing. Also, we welcome you to call with any feedback, questions or comments.

Thank you for your order. We look forward to a long and safe business relationship.



### BAYNETS Safety System Specifications

Netting .....	5 mm High Tenacity Multi-filament Polypropylene Raschel netting with a burst strength of 3.2 kN
Mesh .....	2.5 inch (60 mm) square
Rope .....	1/2 inch diameter Steel-Line™ synthetic rope with a 5700 lb tensile strength. The rope woven through the perimeter mesh of the net and attached to the rope using aluminum pressed rings, 15 inch o.c.
Cable .....	3/8 inch 7x19 galvanized aircraft cable (7,000 lb breaking strength)
Quick Link.....	3/8 inch at 15 inch intervals (3,400 lb safe working load)
Spring Snap Hook .....	7/16 inch (2,450 safe working load)
Frame .....	The frame for the net is made from 3/8 inch aircraft cable and consists of #2 pad eyes and cab-lugs (5,000 safe working load) with 1/2 inch x 6 inch J&E turnbuckles (2,000 safe working load) at one end and 3 Crosby clips at the termination end. The frame is supported with additional pad eyes and snap hooks at approximately 15' o.c. to reduce the sag of long cable runs.
Overall System .....	The resultant safe working load exceeds normal standards by a safety ratio of 10 to 1 (approximately 6,900 lb breaking strength)

### Certificate of Warranty

This Certificate of Warranty for the specified model BAYNETS Safety System becomes valid and Warrants to the purchaser to be free from defects in workmanship and materials for a period of 12 months from date of receipt of equipment. This warranty does not cover failures resulting from misuse, abuse, and alterations of the BAYNETS Safety System with improper components or failure to comply with the proper installation as set forth in the "Instructions for Proper Installation".

To make claim under this warranty, the purchaser must notify BAYNETS, at its office at 226 Upton Road in Colchester, Connecticut. The claim will be evaluated and if bona fide, further instructions will be issued. BAYNETS obligation under this warranty is limited to the option of repairing at its plant or supplying a replacement for component part(s) of the BAYNET System.

There is no other express warranty. Implied warranties, including those of merchantability and fitness for a particular purpose are limited to twelve months from the purchase and to the extent permitted by law any and all implied warranties are excluded. This is the exclusive remedy and liability for consequential and incidental damages under any and all warranties are excluded to the extent exclusion is permitted by law. Some states do not allow limitations on how long an implied warranty lasts, or the limitation or exclusion or consequential or incidental damages, so the above limitations or exclusions may not apply to you.

This warranty gives you specific legal rights and you may also have other rights, which vary from state to state.



226 Upton Road  
Colchester, CT 06415  
800-331-0731  
860-537-1414

[www.baynets.com](http://www.baynets.com)  
email [info@baynets.com](mailto:info@baynets.com)

BNS38-D BayNets Safety System  
Installation Instructions 111  
11-10 Rev. E  
Copyright © 2010 INCORD